



产品规格书

SPECIFICATION

客户名称 **Customer:** _____

样品型号 **Model:** BK16105-0412I12WLSG(H-H2)

客户料号 **P/N:** _____

打印日期 **Print Date:** _____

| 供应商确认 | | | 客户确认 | | |
|---------------------------|-------------|----------------|-----------------------|-------------|----------------|
| Manufacturer confirmation | | | Customer confirmation | | |
| 制作 Formulate | 审核 Audit | 批准 Approval | 测试 Tester | 审核 Audit | 批准 Approval |
| | | | | | |
| | | | | | |

用“芯”创造健康舒适、智慧人文的照明环境

High quality COB lighting ---Create a healthy, comfortable, intelligent and humanistic lighting environment

*规格书如有变更恕不另行通知;

*规格书最终解释权归佛山市中昊光电科技有限公司所有;

*Specifications are subject to change without prior notice;

*Foshan Evercore Optoelectronic Technology Co., Ltd. has the right to interpret the specifications



目录 Catalogue

| | |
|---|---|
| ➤ 应用范围 Application | 3 |
| ➤ 产品尺寸 Product dimensions..... | 3 |
| ➤ 产品特点 Product characteristics | 3 |
| ➤ 光电参数 Basic parameters | 4 |
| ➤ 极限参数 Limit parameters | 4 |
| ➤ 特性曲线 Reliability test curve | 5 |
| ➤ 分光标准 White bins on CIE | 6 |
| ➤ 包装说明 Package and label illustration | 7 |
| ➤ 产品编码 Coding rules | 8 |
| ➤ 测试项目 Test items | 8 |
| ➤ 注意事项 Announcements | 9 |

➤ 应用范围 Application

| 导轨灯 Tracking Light | 射灯 Spot Light | 帕灯 Par Light | 球泡 Bulb Light | 筒灯 Down Light |
|---|---|---|---|---|
|  |  |  |  |  |

➤ 产品尺寸 Product dimensions

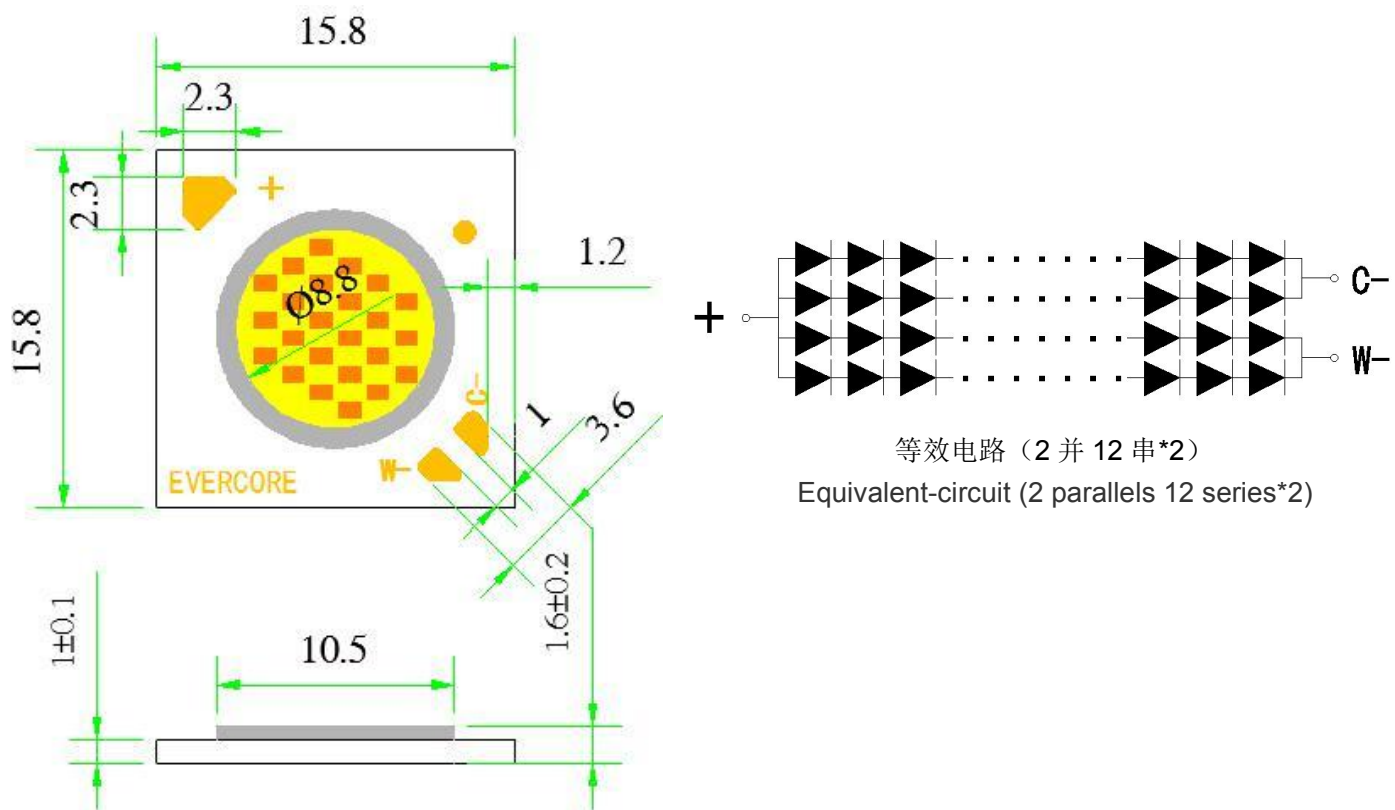

*尺寸单位：mm，无特殊说明，公差为±0.2mm

Unit : mm, tolerance±0.2 unless stated otherwise

➤ 产品特点 Product characteristics

- 1) 光色一致性好、高亮度、高光效； Good consistency of light color, high flux , high efficiency;
- 2) 低热阻，热稳定性好； Low thermal resistance, good thermal stability;
- 3) 兼容性强，易于安装使用； Strong compatibility, easy to install and use;
- 4) 产品可靠性高； High reliability;

➤ 光电参数 Basic parameters (Ta=25°C)

| 产品型号 | 测试条件 Testing Conditions | 色温 CCT | current 电流(mA) | 光通量 Luminous flux(LM) | | Ra Min. | R9 Min. | thermal resistance Rj(°C/W) |
|----------------------------|--|-----------|-------------------|--------------------------|------|------------|------------|-----------------------------------|
| | | | | Min. | Typ. | | | |
| BK16105-0412112W LSG | Tc=25°C If: W(暖色电流) (current-Warm white) C(冷色电流) (current-Code white) | 2700K | W280+C0 | 965 | 1050 | 80 | 0 | 1.5 |
| | | 3000K | - | - | - | | | |
| | | 3500K | - | - | - | | | |
| | | 4000K | W145+C135 | - | - | | | |
| | | 4500K | - | - | - | | | |
| | | 5000K | - | - | - | | | |
| | | 5700K | - | - | - | | | |
| BK16105-0412112W LSH-H2 | | 2700K | W280+C0 | 810 | 880 | 90 | 50 | |
| | | 3000K | - | - | - | | | |
| | | 3500K | - | - | - | | | |
| | | 4000K | W145+C135 | - | - | | | |
| | | 4500K | - | - | - | | | |
| | | 5000K | - | - | - | | | |
| | 5700K | - | - | - | | | | |
| 6000K | W0+C280 | 995 | 1080 | | | | | |

Note: device tolerance 1)光通量±5% for luminous flux:±5% 2) 电压±3% Voltage±3%
3)色坐标: ±0.002 device tolerance for color coordinate:±0.002 4) Ra/R9±2

➤ 极限参数 Limit parameters (Ta=25°C)

| 参数 Parameters | 符号 Symbol | Min | Typ | Max | 单位 Unit |
|----------------------------|-----------|-----|-----|------|---------|
| 正向电压 Forward V | Vf | 34 | 36 | 40 | V |
| 正向电流 Forward A | If | - | 280 | 450 | mA |
| 功率 Power | Pi | - | 12 | 18 | W |
| 结温 Junction Temp | Tj | - | 110 | 125 | °C |
| 静电 Attractions(HBM) | - | - | - | 8000 | V |
| 出光角度 View Angle | 2θ1/2 | - | 120 | - | degrees |
| 工作温度 Operation Temperature | Top | -10 | - | +85 | °C |
| 储存温度 Storage Temperature | Tst | -40 | - | +100 | °C |
| 焊接温度 welding temperature | Tsol | - | - | 400 | °C |

*Ta=25°C使用时,Tc≤85°C; 实际使用环境下, 硅胶面温度≤130°C;

*Ta=25°C Bonding pad Tc < 85°C. In actual condition, silica gel surface temperature of ≤130°C

特性曲线 Reliability test curve

1、温度与光通量曲线图 Temperature Vs Lumen

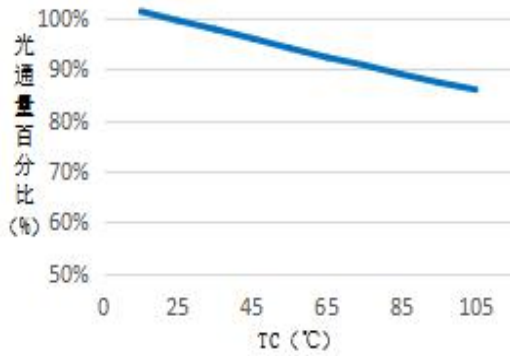

2、Tc-If 曲线图 TC VS IF curve

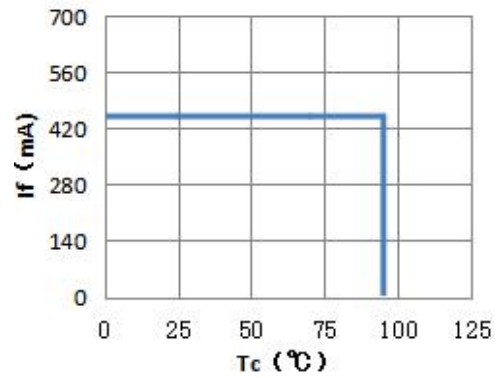

3、电流与光通量曲线图 Current Vs Lumen

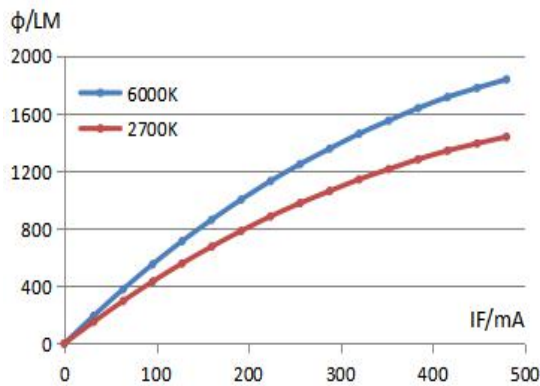

4、伏安特性曲线 Voltage Vs Current

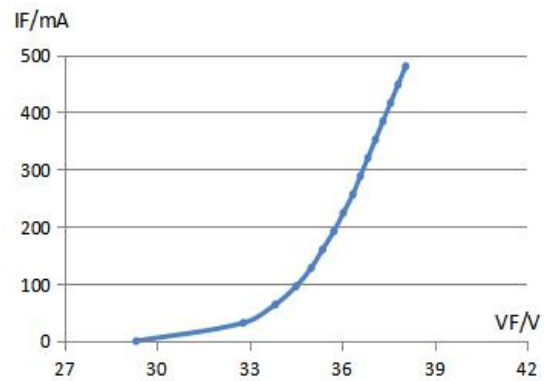

5、相对光谱曲线图 Relative spectral curve

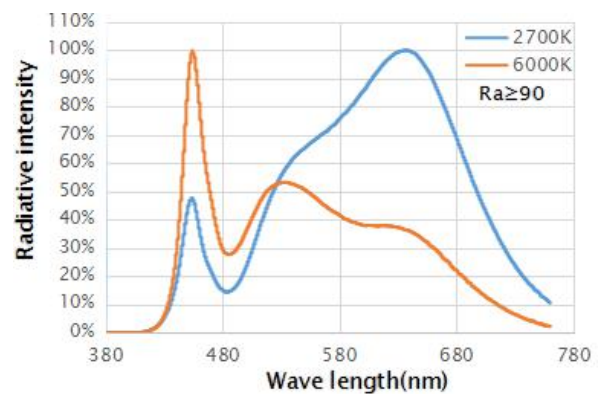
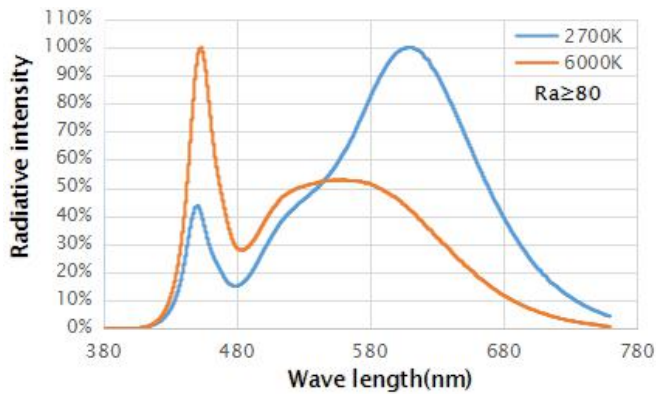

6.7 产品光分布图 Light distribution diagram

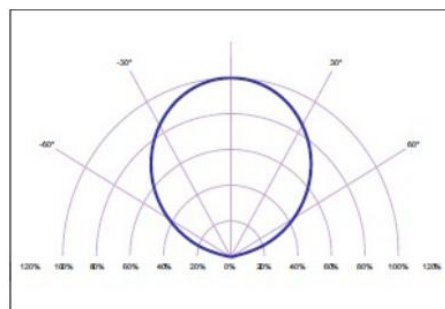
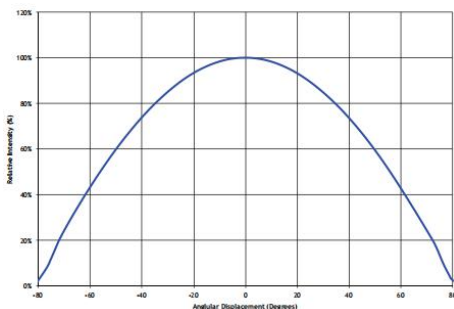

*以上曲线图为光源特性数据，仅供参考。

➤ 分光标准 White bins on CIE-1931 (Ta=25°C)

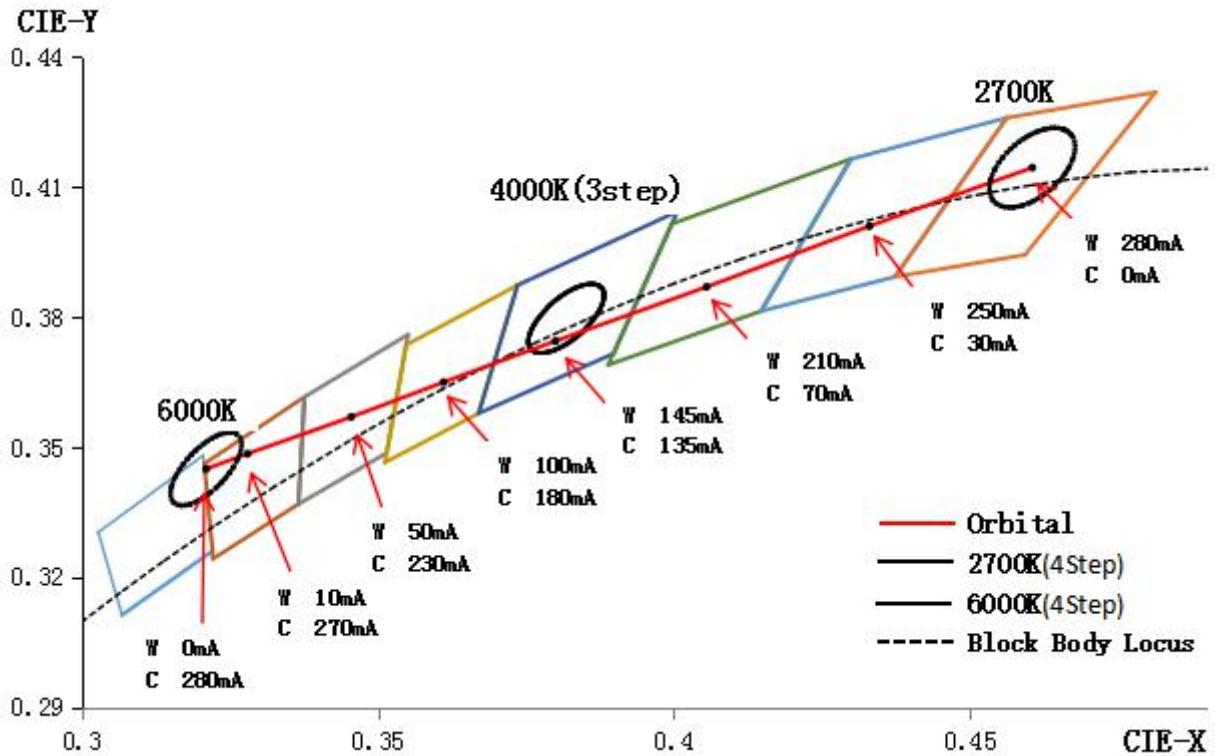

色温分 BIN Color Temperature and BIN

| | | |
|----------------|-----------|-----------|
| 色温 CT | 2700K | 6000K |
| 色温范围 CT Range | 2600-2800 | 5950-6650 |
| 色温系数 CT Factor | ±100 | ±350 |
| 并号 Bin NO. | L4 | S4 |

| 色温 CCT | 显指 (Ra) | 色容差 chromaticity tolerances | 中心点坐标 Central point coordinates | | 长轴 long axisa | 短轴 Short axis b | 旋转角度 Rotation AngleΘ |
|--------|---------|-----------------------------|---------------------------------|--------|---------------|-----------------|----------------------|
| | | | X | Y | | | |
| 2700K | 80 | 4SDCM | 0.464 | 0.41 | 0.01032 | 0.00548 | 25.00 |
| | 90 | | 0.459 | 0.4163 | | | |
| 6000K | 80/90 | | 0.321 | 0.345 | 0.0096 | 0.00388 | 58.60 |

*产品按标准电流分色测试，若使用其他电流工作，光色会发生变化。

*客户如使用 IEC 标准，请下单前提前说明，我司会及时调整标准以满足贵司要求。

Product color sorting test according to standard current, if using with other current, light/color will change.

If customers need specific IEC standards, please let us know before placing an order. We will adjust the standards to meet your special requirements.

➤ 包装说明 Package and label illustration

1) 包装方式: 吸塑盒+静电袋真空包装+外箱

COB Packing : Tray + Anti-static bag with vacuum packing + outer boxes

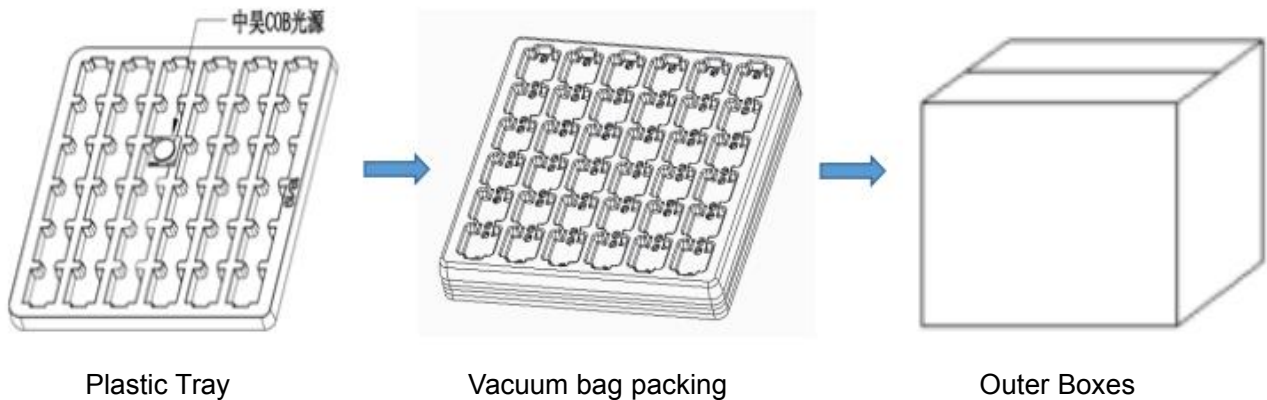

2) 外箱规格尺寸 Box dimensions

| 外箱规格 Box Size | 长 Length (mm) | 宽 Width (mm) | 高 Height (mm) |
|---------------|---------------|--------------|---------------|
| 大箱 Big | 38.5 | 38.5 | 23 |
| 中箱 Medium | 33 | 23 | 19 |

3) COB 产品包装数量说明

| 产品型号 PN base | 片/盒 PCS/BOX | 盒/包 Tray/bag | 片/包 Pcs/bag | 包/片/大箱 Bag/ pcs Big box | 包/片/中箱 bag/Pcs/Medium box |
|----------------------|----------------|-----------------|----------------|----------------------------|------------------------------|
| BK1306/BK1375/BK1308 | 36 | 5 | 180 | 24/4320 | 10/1800 |
| BK16105/BK1611 | 30 | 5 | 150 | 24/3600 | 10/1500 |
| BK1814/BK1914/BK1917 | 25 | 5 | 125 | 24/3000 | 10/1250 |
| BK28245 | 16 | 5 | 80 | 26/2080 | 10/800 |

4) COB 产品背部喷码规则 Coding rules for the back printing of COB

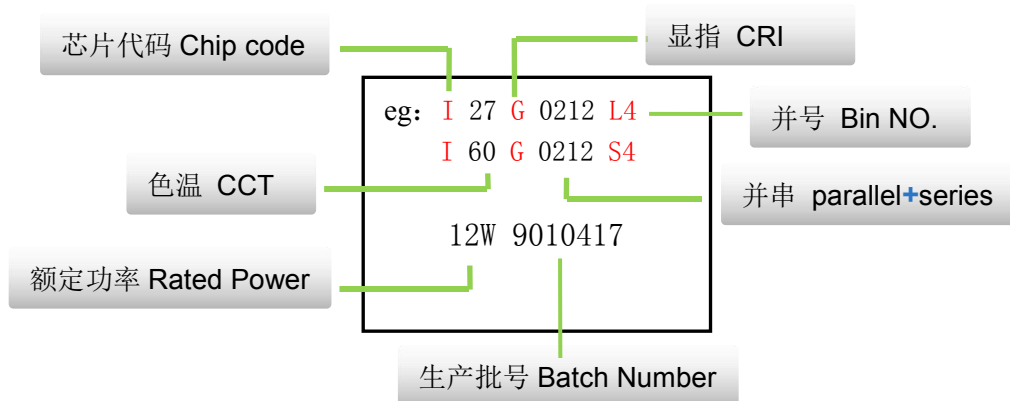

➤ 产品编码 Coding rules

B K16 105-04 12 I 12W LS G-XXXX

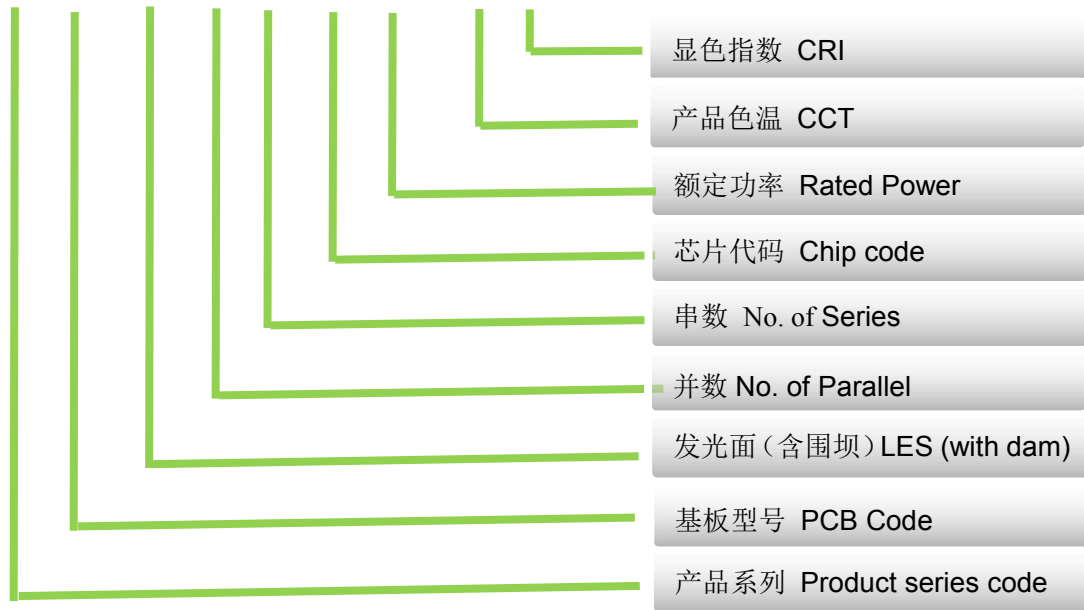

➤ 测试项目 Test items

| 类别 Type | 试验项目 | Test items | 参考标准 standards | 试验条件 Test conditions | 持续时间 duration | 取样数 Sample quantity | 接收水准 result |
|---------------------------------|---------------|-----------------------------------|-----------------------------|--|---------------------------|---------------------------|----------------|
| 环境 试验 Environment test | 温度循环 | Temp. cycle | JEITA ED-4701 100 105 | -40℃→25℃→ 100℃→25℃ 30Min 5Min 30Min 5Min | 循环 300 回合 (300 cycles) | 5 | 0/5 |
| | 高温储存 | Storage with high temp | JEITA ED-4701 200 201 | Ta=100℃ | 168 小时/hrs | 5 | 0/5 |
| | 低温储存 | Storage with low temp | JEITA ED-4701 200 202 | Ta=-40℃ | 168 小时 hrs | 5 | 0/5 |
| 寿命 试验 Life test | 常温寿命 试验 | room temp | - | Ta=25℃ @If | 1000/3000/600 0 小时/hrs | 1 | 0/1 |
| | 高温寿命 试验 | high temp | - | Ta=85℃ @If | 1000 小时/hrs | 1 | 0/1 |
| | 高温高湿 寿命试验 | high temp and high humidity | - | Ta=85℃ Rh=85% @If | 1000 小时/hrs | 1 | 0/1 |
| | 大电流常温 寿命测试 | High power with Room Temp | - | @1.5*If | 720 小时/hrs | 1 | 0/1 |
| | 开关实验 | Soldering resistance | IEC62717 | @If Tc=85℃ 30s on/30s off | 30000cycle | 2 | 0/2 |

➤ 注意事项 Announcements

1) 储存条件 Storage condition

储存环境湿度<60%，温度保持在 20℃-30℃，已开封 COB 光源请在 168H 内安装完毕，如未能及时使用完，请抽真空后密封保存，密封保存后有效使用期为 1 年；

The storage environment humidity is <60%, the temperature is maintained at 20℃-30℃. Once the COB light sources have been unsealed, please install them within 168H; if it is not used up within 168H, please vacuum it and keep it sealed. After sealing, the effective use period is 1 year.

2) 使用注意事项 Application notice

焊接时，烙铁应正确接地，手工焊接时，烙铁的温度必须低于 400℃，一次焊接时间不超过 3 秒，冷却至室温后才能再次焊接，焊接时请注意不可有外力作用于胶体表面及围坝胶上（如压力，摩擦或锋利金属钉等），以免造成金线变形或断线等异常。

When welding, the soldering iron should be properly grounded. When manual welding, the temperature of the iron must be lower than 400℃, welding time shall not exceed 3 seconds and shall be cooled to room temperature before welding again. When welding, no external force should be put on the colloidal surface and the surrounding dam glue (such as pressure, friction or sharp metal nails, etc.) or it will cause deformation of gold wire or broken wire...

为确保在组装时降低接触热阻，请注意导热膏涂布均匀且分布面积合理，不可出现导热膏太少或涂抹高低不平等现象。如使用导热胶垫时，请确保螺丝安装后基板与导热胶垫的完全接触，不可存在中空现象。

In order to reduce the contact thermal resistance during assembling, please note that the thermal conductivity paste coating is uniform with proper distribution area, too little thermal conductivity paste or uneven application level is not okay. When using thermal conductive rubber pad, make sure that the base plate and thermal conductive rubber pad are in complete contact after screw installation, No hollow space is allowed.

焊接后请不要让导热硅脂、油等接触到发光面，污垢可用气枪去除，不可用含硫、氯元素液体或洗板水等进行清洗。气枪压力：0.5MPa，时间 1 - 2 秒，距离：隔开 20cm 以上。

After welding, please do not let the heat conduction silicon grease, oil... to the luminous surface, dirt can be removed with an air gun, do not use sulfur, chlorine element liquid or washing board water to clean, Air gun pressure: 0.5mpa, time 1-2 seconds, distance: more than 20cm apart.

3) 静电防护 Electrostatic protection

本产品对静电敏感，所以在使用本产品时必须采取有效的防护措施，能有效的防止静电和电涌对 LED 光源的损害，当静电产生的高压电流超过 LED 光源的最大额定值时，会导致 LED 光源的损坏，甚至完全失效。客户使用产品时，应采取有效的防止静电和电涌的对应措施。建议接地电阻 ≤10Ω；

This product is sensitive to static electricity, so effective protective measures must be taken when using this product to effectively prevent the damage of LED light source from static electricity and surge. When the high voltage current generated by static electricity exceeds the maximum rating of LED light source, the LED light source will be damaged or even completely invalid. Therefore, Customers should take effective measures to prevent static electricity and surge when using the products. Suggested grounding resistance is 10Ω or less.

4) 过温过流保护 Over-temperature, over current protection

任何时候严禁按压发光胶体部分，以免光源表面不良甚至失效。建议整灯设计时有接地电路。
Do not press the luminous silicon surface at any time to avoid bad effect or even ineffective to the COB. It is recommended to design grounding circuit for the whole lamp design.

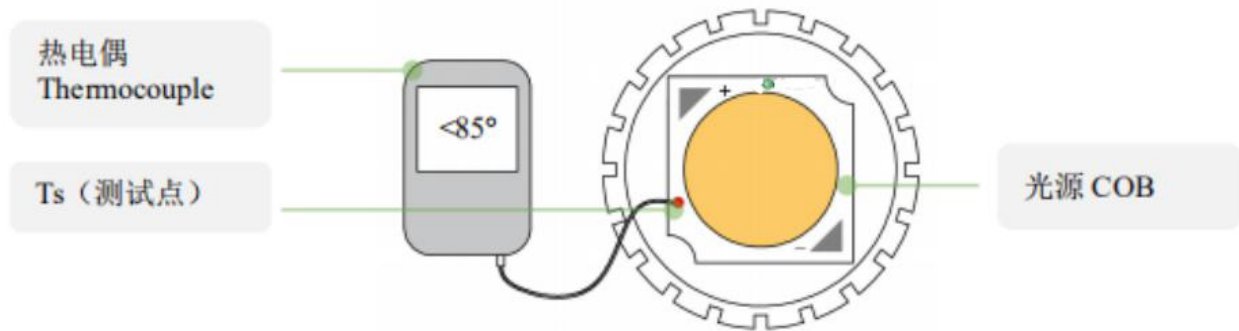

LED 光源使用湿度在 50%~80%之间，工作环境在-10℃~85℃中使用，否则会有静电击穿和大电流冲击隐患。使用本产品时请保证在规格书注明的最大额定值（最大电流及 Tc 和胶面温度）内使用，如未遵守产品规格书的最大额定值及说明而产生的不良后果，不在中昊承诺质保范围之内。

The working humidity is between 50% and 80%, and the working environment is between -10℃ and 85℃, otherwise, there will be hidden dangers of electrostatic breakdown and large current impact. When using this product, please ensure that it is used within the maximum rating (maximum current and Tc and glue surface temperature) specified in this specification. Any adverse consequences arising from failure to comply with the maximum rating and description of the product specifications shall not be covered by the warranty.

5) 散热设计 Thermal design

LED 光源的良好运行取决于 LED 光源热阻、外部导热热阻、功率损耗和环境温度。
LED 结温过高将影响光通量和光源寿命。在散热设计时应充分考虑这些因素。

A good use effect of LED light source depends on the thermal resistance of LED light source, external thermal resistance, power loss and ambient temperature.

High junction temperature of LED will affect the light flux and the working life of the light source. Full consideration of these factors is highly recommended in heat dissipation design.